



IoT Smart Doggy Door



Group 15 - Dr. Chan

Jordan Carraway - EE
Hunter Herrold - EE
Alexis Quintana - CpE/EE
Logan Waln - CpE





Goals and Objectives

- Create a doggy door that is rich with features, easy to use and capable of implementing new ideas
- Enable remote user control with a mobile application
- Have long lasting, affordable, and easy to replace collars
- Make the door as compact as possible
- Supply the door with two power sources
- Allow offline operation
- Create a responsive system
- Add an auditory cue for the dog to learn from



Requirement Specifications

- Door dimensions (flap and overall size)
- Strength of flap
- Detection/reading distance
- System processing time
- Door flap locking distance
- Buzzer noise level
- Duration of external battery life

Description	Parameter	Specification
Door flap dimensions	Dimensions of the door flap	W: 0.25" L: 12" H: 19"
Door frame dimensions	Dimensions of the whole door setup	W: 8", L: 12", H: 22"
Durability of flap	How much force the door flap can withstand	63 N/mm ²
Tag collar reading distance	How far the tag should be read from the door	0.5 m - 1 m
Infrared detection distance	How far the infrared sensor detects movement	0.5 m - 1.5 m
Tag process and door unlock time	The duration at which the tag should be read, processed, and the door unlocked	< 4.5 seconds
Door flap locking distance	How far the locks should be placed from the door flaps resting position	< 4"
Sound pressure level of buzzer	How loud the buzzer should be	70 dB - 90 dB
External battery life	Duration of the battery life	1 hour - 1.5 hour

Table 1: Requirement Specifications

House of Quality

- Strived for ease of use and reliability
- Willing to compromise on aesthetics and cost to create a better product overall



Correlations	
Positive	+
Negative	-
No Correlations	

Relationships	
Strong Positive	▲
Positive	△
Neutral	○
Negative	▽
Strong Negative	▼

		<table border="1" style="width: 100%; text-align: center;"> <tr> <td></td><td>+</td><td>-</td><td>+</td><td>-</td><td>+</td><td>-</td> </tr> <tr> <td></td><td>-</td><td>+</td><td>-</td><td>+</td><td>-</td><td>+</td> </tr> <tr> <td></td><td>+</td><td>-</td><td>+</td><td>-</td><td>+</td><td>-</td> </tr> <tr> <td></td><td>-</td><td>+</td><td>-</td><td>+</td><td>-</td><td>+</td> </tr> <tr> <td></td><td>+</td><td>-</td><td>+</td><td>-</td><td>+</td><td>-</td> </tr> <tr> <td></td><td>-</td><td>+</td><td>-</td><td>+</td><td>-</td><td>+</td> </tr> </table>							+	-	+	-	+	-		-	+	-	+	-	+		+	-	+	-	+	-		-	+	-	+	-	+		+	-	+	-	+	-		-	+	-	+	-	+
	+	-	+	-	+	-																																											
	-	+	-	+	-	+																																											
	+	-	+	-	+	-																																											
	-	+	-	+	-	+																																											
	+	-	+	-	+	-																																											
	-	+	-	+	-	+																																											
		Column #	1	2	3	4	5	6																																									
Customer Requirements (Explicit and Implicit)	Engineering Requirements	Accuracy																																															
		Operation Time																																															
		Quality																																															
		Smartphone Operations																																															
		Size																																															
		Cost of Production																																															
	Aesthetics	▲	○	○	○	▽	▽																																										
	Ease of Use	○	○	▲	▲	○	○																																										
Reliability	○	○	△	△	○	▼																																											
Range	○	▽	△	○	▽	▼																																											
Security	▽	▽	△	△	○	▽																																											
Cost	○	○	▼	○	▽	▼																																											
Target		Beamwidth +/- 20°	< 4.5 seconds	Withstand for 1-2 years	Query database < 4 seconds	< H:22", W:4", L:12"	< \$700																																										



Plan of Approach

- Compartmentalize the system into individual parts
 - Mechanical
 - Precise measurements
 - Electrical
 - PCB
 - Software
 - System Controller
 - Database
 - Mobile Application



Hardware Diagram

- Switching module for external battery and wall adapter
- Each assigned primaries and secondaries

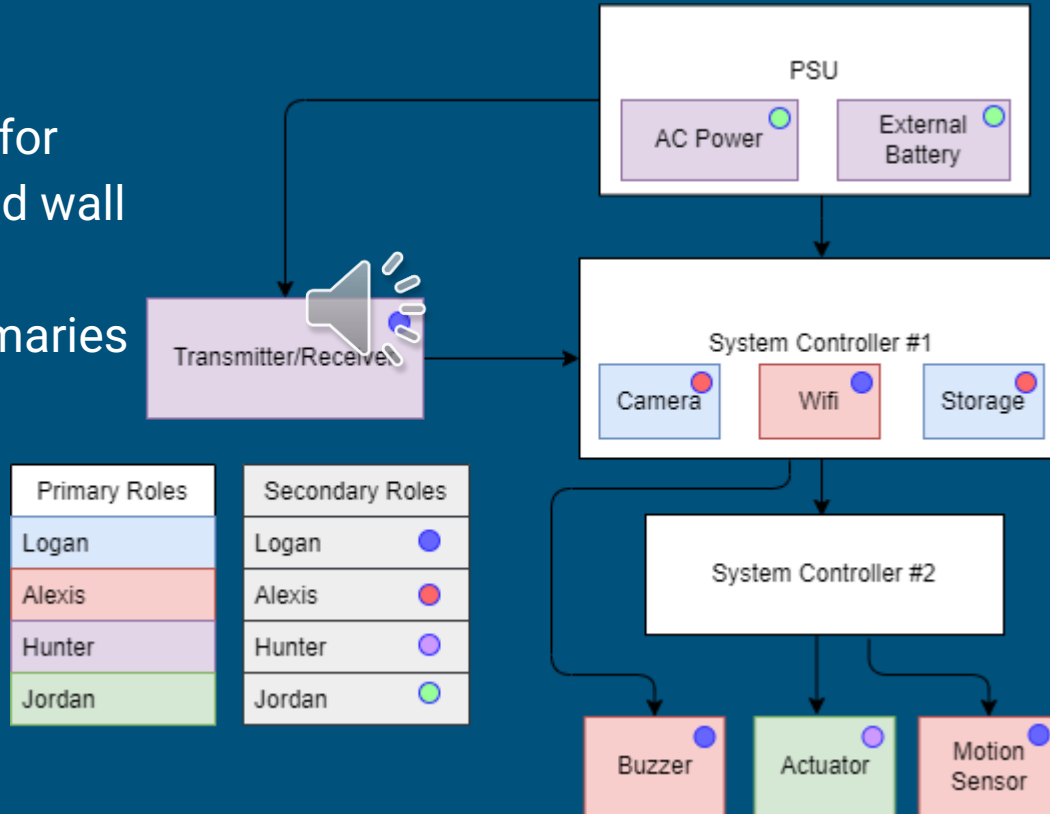



Software Diagram

- Software setup using database and mobile app for IoT integration
- Workload split between front end and back end tasks

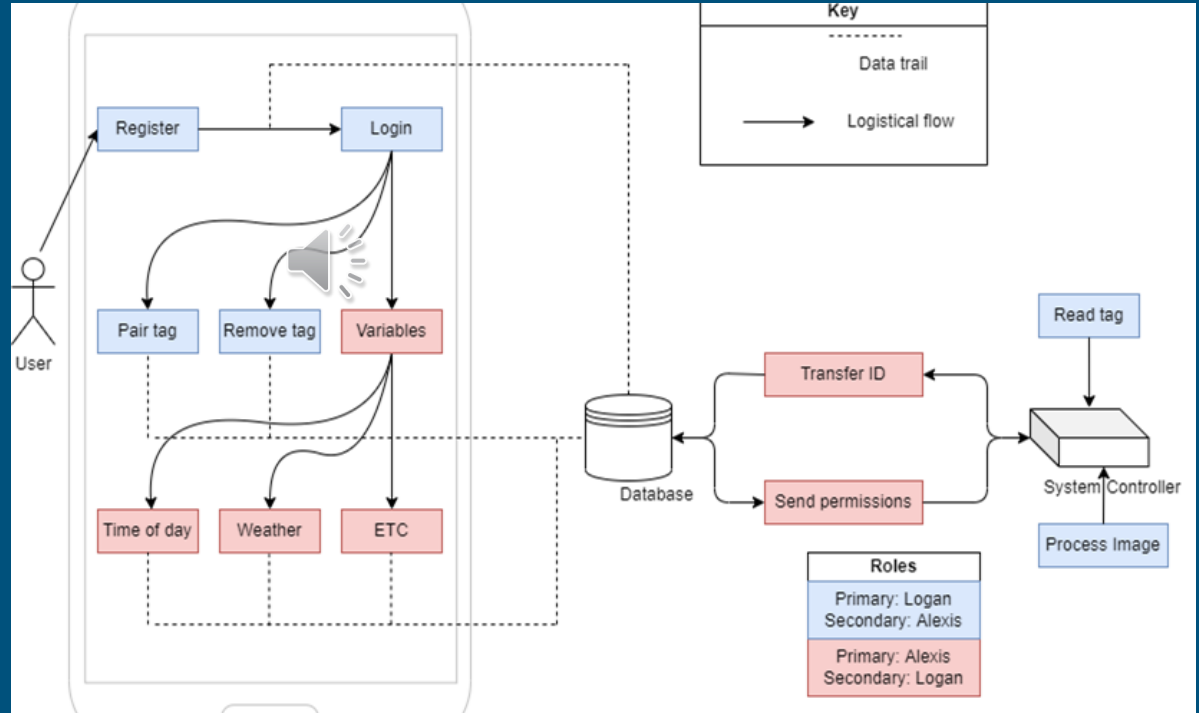

System Controllers

	ATmega382P	MSP430
Architecture	Advanced RISC architecture	Older, von-Neumann architecture
Power Consumption	Low & Efficient	Low
Performance	Medium, suitable for decently complex projects	Low, suitable for simple projects
Ease of Use	Easy to use	Complex

	Raspberry Pi Zero W	Raspberry Pi Pico	Raspberry Pi 4 B
Description	The iconic, cheap, small Pi Zero with wifi and bluetooth	Raspberry Pi microcontroller	Fourth edition of the mainline Raspberry Pi devices
Price	\$10	\$4	\$35
Dimensions (HxWxD) in inches	1.18 x 2.55 x 0.197	0.83 x 2 x 0.154	2.22 x 3.37 x 0.433
Weight in grams	9	3	46
Number of cores	1	2	4
Clock speed	1 GHz	133 MHz	1.5 GHz
RAM	512 MB	264 KB	1, 2, 4, or 8 GB
Ethernet	No	No	Yes
GPIO pins	40	26	40
Storage/Operating System	Yes, microSD/Raspbian	No	Yes, microSD/Raspbian
Wi-Fi	802.11n (only 2.4GHz)	No	802.11 b/g/n/ac (2.4 and 5 GHz)
Bluetooth	4.1 BLE	No	5.0





Pinout Diagrams

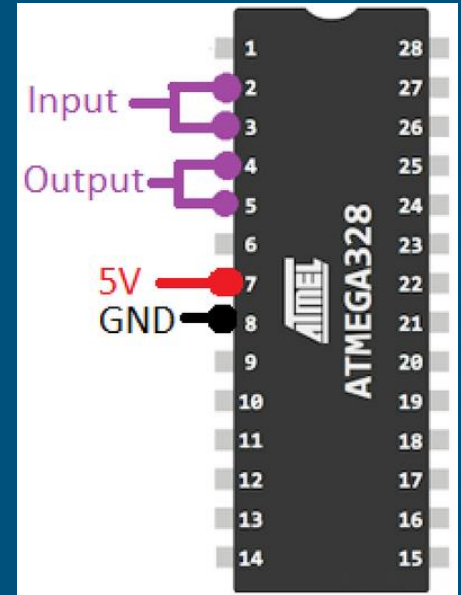
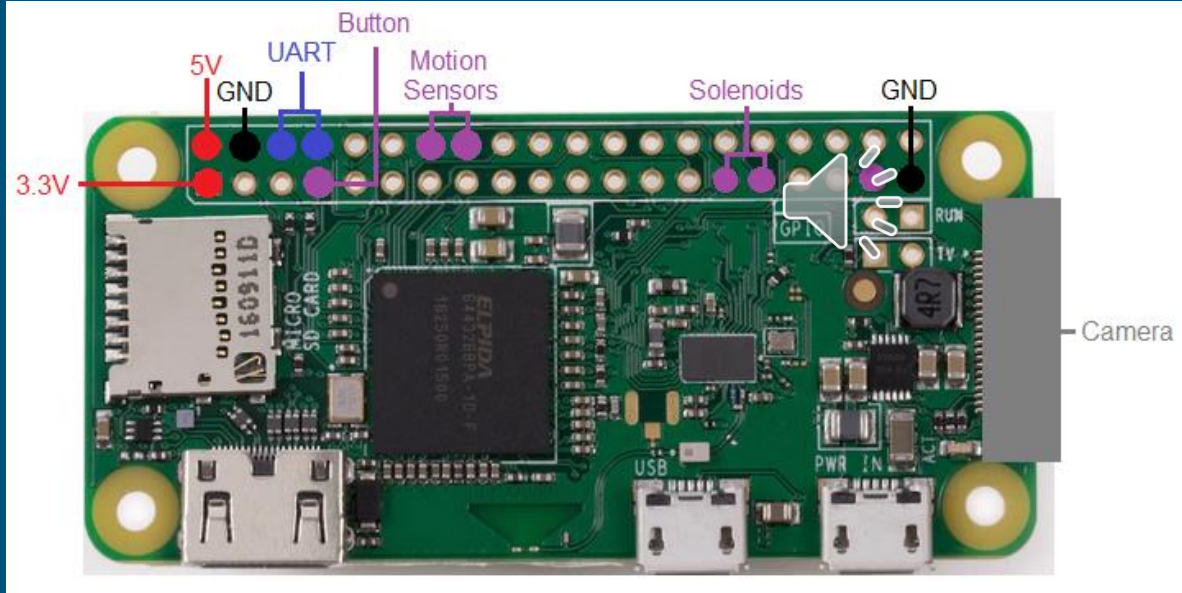

Power Requirements



- System power requirements
 - Two voltage rails: 12 VDC and 5 VDC
- AC/DC converter posed more interesting of a PCB
- DC/DC converter module therefore bought instead
- All current values are maximum ratings

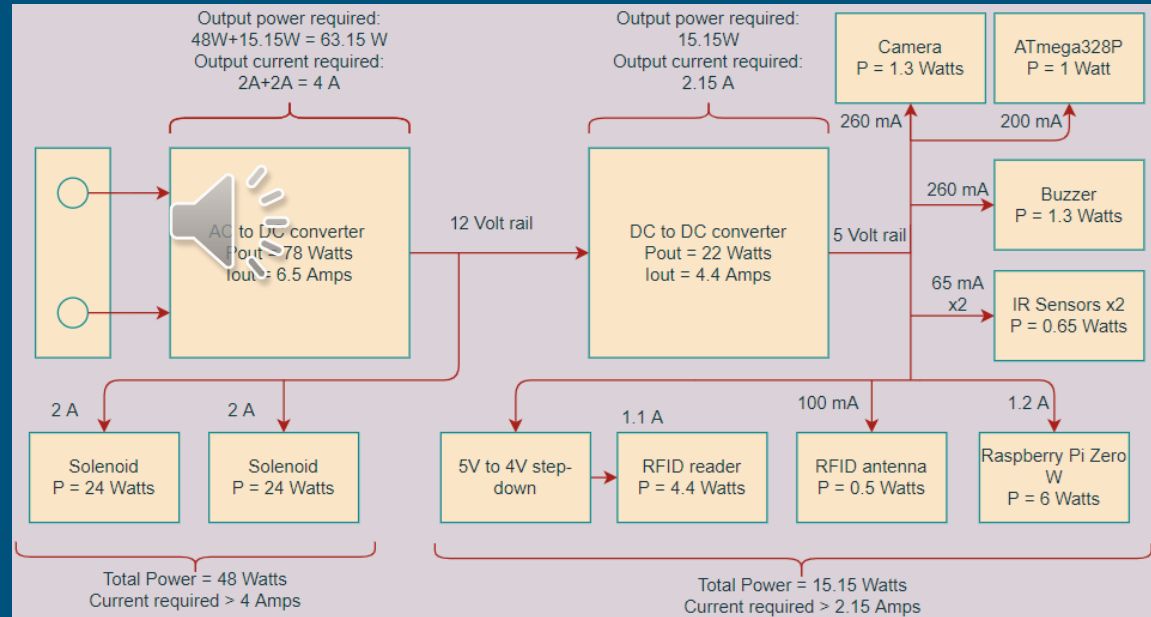

Significant PCB Design



- PSU AC/DC converter topologies
- Tradeoffs between efficiency and simplicity
- LLC controllers introduced many luxuries, but the complexity was unnecessary
- PFC controllers' disadvantages outweighed the simplicity
- Flyback was an acceptable compromise between what we were looking for

Topology	Advantages	Disadvantages
Flyback Controllers 	<ul style="list-style-type: none">● Mutually coupled inductors isolate the input from the output (no need for additional circuitry)● Capable of providing multiple different output voltages, each separated from input● Simplistic design (very few components required)	<ul style="list-style-type: none">● Unable to produce too high of an output current/power● The transformer gap results in more EMI● Greater ripple current
LLC controllers	<ul style="list-style-type: none">● Reduced EMI, ZVS, ZCS● High efficiency● Large range of output power and output current● Lower BOM cost in regards to output inductors	<ul style="list-style-type: none">● Complex/sophisticated design, requiring extensive research for design and control● Difficult frequency tuning
(PFC) Controllers	<ul style="list-style-type: none">● Simplistic design● Financially affordable due to a lack of complicated hardware components	<ul style="list-style-type: none">● Small range of input voltages● Large and bulky, also quite heavy

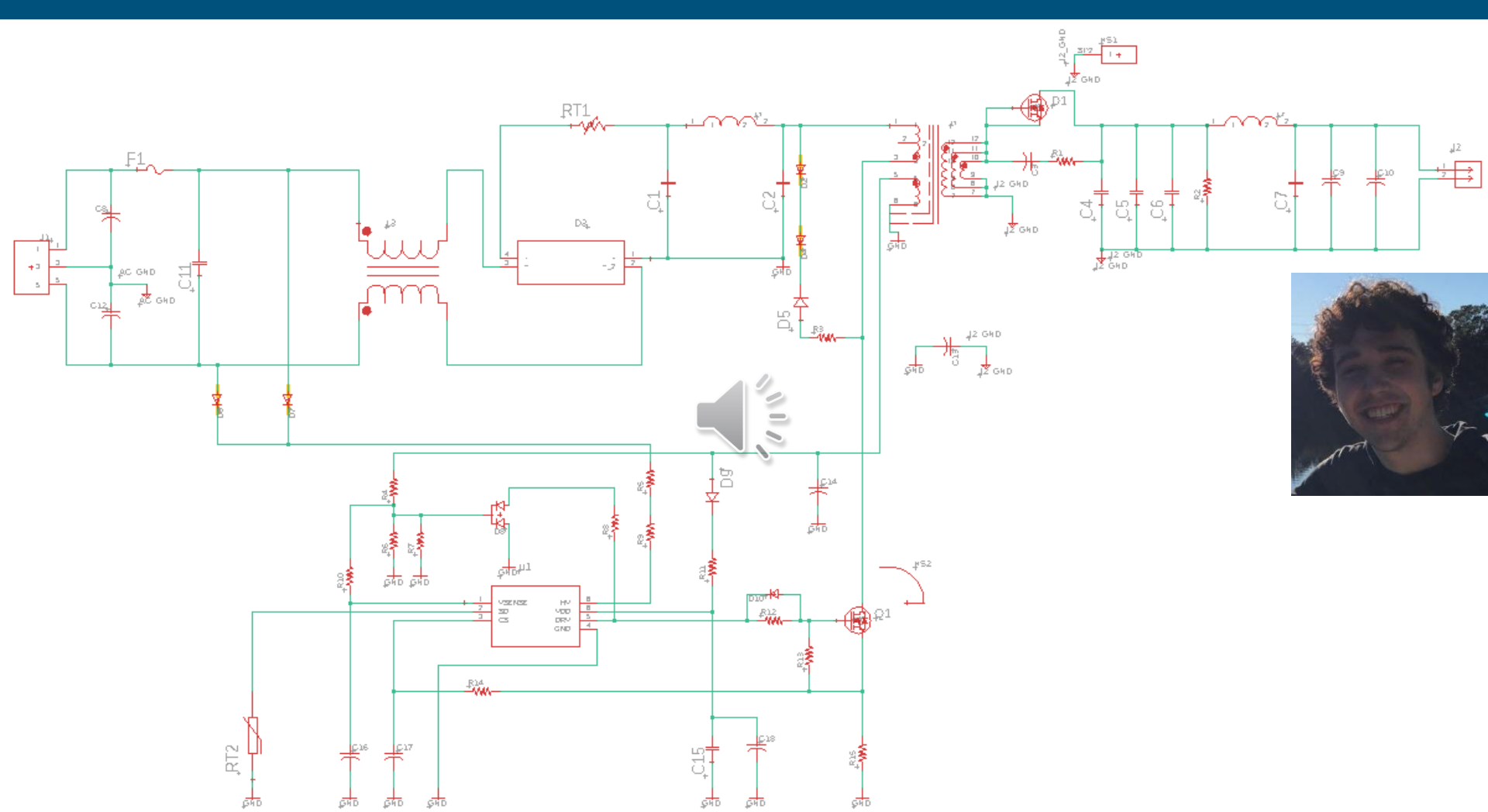

Significant PCB Design Cont.



Pulse Width Modulation (PWM) controller

- Primary-side regulated (PSR) flyback controller
- VDD pin; powered through auxiliary winding
- HV pin; high voltage input,
- DRV output pin; high power MOSFET control
- VSENSE pin monitoring; VDD input voltage, DRV output voltage
- CS pin; current sensing
- SD pin; safety fault mode
- GND pin; connecting IC's ground

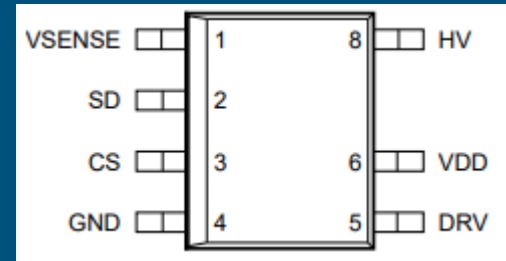

Significant PCB Design Cont.

- Additional PCB with a programmable microcontroller
 - Actuation: Solenoid Driver
 - ATmega328P communicating to the Raspberry Pi
- Includes I/O ports for 5V rail and 12V rail

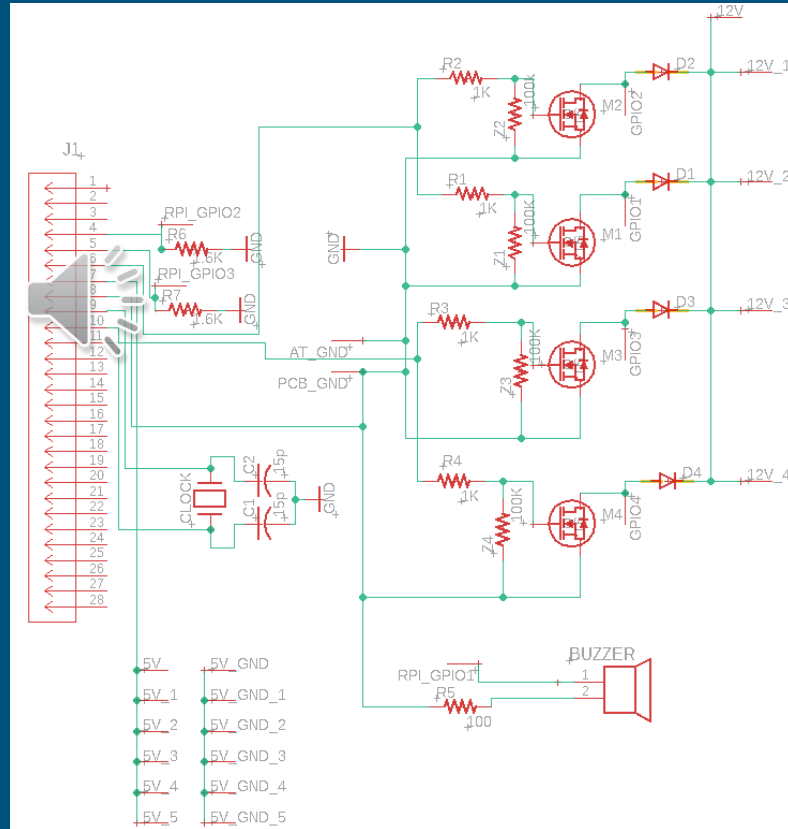

Battery Bank and Switching Module



- Battery bank in case of power outage
 - Rechargeable 12V 8300mAh Lithium ion Battery Pack
 - 12V/6A barrel jack input/output
 - 9V/1A barrel jack output
 - 5V/2A USB output
- Switching module for battery bank and wall adapter
 - Outputs input 1 by default, unless input 1 drops below a certain voltage, then switches to input 2

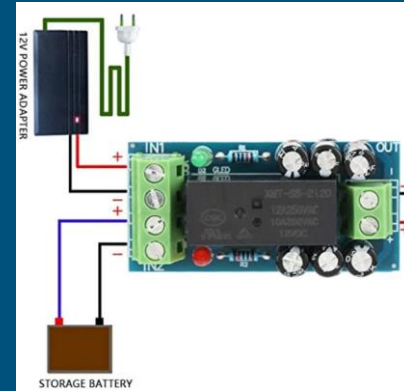

Doggy Door Materials and Construction



- The doggy door is constructed using wooden planks 8" wide and $\frac{3}{4}$ " thick
- Space on each side of the door to house the locking mechanism and solenoids 
- Flap is made of a polycarbonate sheet to increase durability
- Top portion houses the remaining hardware components



Doggy Door Locking Mechanism



- 3 pieces locking mechanism consisting of the locking pins, knobs, and shaft
- The design of the pins allow for the flap to work unidirectional at any given time.
- Solenoids will be used to push the pins up to allow for the door to be opened.



(Knob)

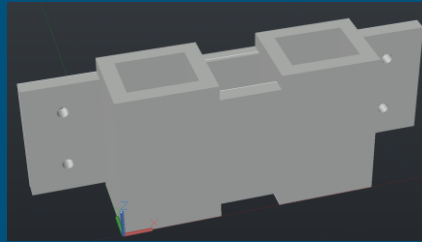

(Shaft)



(Pin)



Doggy Door Locking Mechanism Comparisons



Locking Mechanism	Operating Voltage	Current Draw	Force	Operating Speed	Price	Size
Solenoids	12V DC	1A	20N	Instant	\$11.59	2.2"x1"
Linear Actuator	12V DC	2.3 A	400GN	4.5mm/s	\$59.95	Extended Length: 44.3"
3D Printed Pin	None	None	N/A	N/A	\$21.00	0.75"x0.5"x2"
3D Printed Shaft	None	None	N/A	N/A	Free	1.3"x3.375"x0.812 5"
3D Printed Knob	None	None	N/A	N/A	Free	0.75"x0.5"x1.5"
Electromagnet	12V DC	80mA	6N	Instant	\$29.24	0.75"x0.75"x0.62"

Table 11: Comparisons of the Different Locking Mechanisms

Databases

- Foundation for IoT integration
- Accessible by the mobile application anywhere, at any time
- Decision to go with Firebase

Name	Couchbase	Firebase	MongoDB
Short Description	JSON-based database derived from CouchDB	Cloud-hosted realtime database. All clients share one realtime instance and auto receive updates	Database that works both as a cloud service or a deployed self-managed infrastructure
Cloud-based only?	No	Yes	No
Offline mode?	No	Yes	No
Server Operating System	Linux, OS X, Windows	Hosted	Linux, OS X, Solaris, Windows
APIs and other access methods	CRUD, Query, Search, Analytics API	Android, iOS, Javascript API, RESTful HTTP API	Proprietary protocol using JSON
Triggers	Not immediate	Immediate	Not immediate
MapReduce	Yes	No	Yes
Server-side scripts	Javascript	Potentially limiting Google 'rules'	Javascript



Camera



- Used for capturing images of anything that might be in front of the door
- Decision to go with the Arducam



	Arducam OV5647	Raspberry Pi Camera Mod 1	Raspberry Pi Camera Mod 2
Price	\$14	\$25	\$25
Size	25 x 24 mm	25 x 24 x 9 mm	
Weight		3g	3g
Still Resolution	5 MP	5 MP	8 MP
Sensor Resolution	2592 x 1944 Pixels	2592 x 1944 Pixels	3280 x 2464 Pixels
Full-frame SLR lens equivalent	35 mm	35 mm	
Angle of view	64 x 48 °	53.5 x 41.4 °	62.2 x 48.8 °



Passive Infrared Sensor

- Used to detect any living presence at the door using infrared technology
- Works in conjunction with camera and reader
- Second sensor on inside
- Decision to go with HC-SR501 

	HC-SR501	LEDENET	LPIR-8A
Price	Varies, usually around \$4 per sensor	\$10	\$8
Size (mm)	32 x 24	86 x 51	89 x 60
Field of View	<120 degrees	60 degrees	
Range (ft)	21	16-26	15



Mobile Application

- Software
 - React Native CLI
- Functionality
 - Registration
 - Edit and delete animals
 - Change animal permissions
 - View photos taken by camera

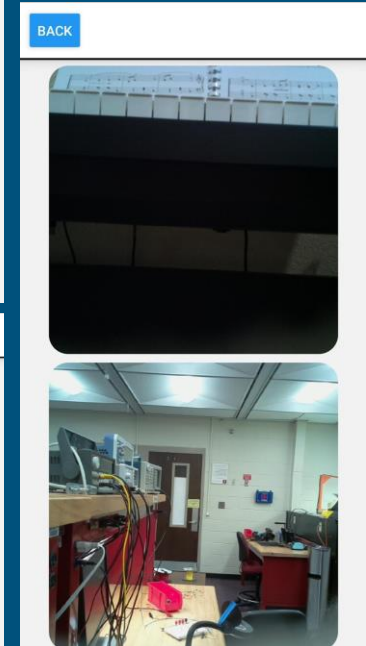
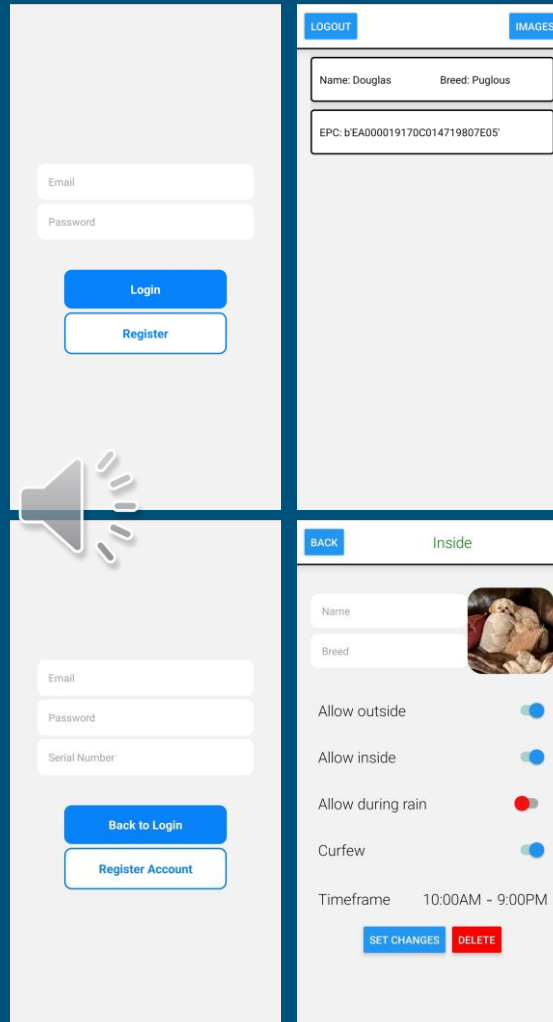

RFID Tags and Frequencies



Frequency ranges:

- **LF: 125 - 134 kHz, 1 - 10 cm**
 - Low susceptibility to EM disturbance, but slow data processing speeds
- **HF: Typically 13.56 MHz (NFC), 1 - 100 cm**
 - Faster transmission and relatively low EM disturbances, but too short of a read range
- **UHF: 865 - 960 MHz, reaching over 30 m**
 - Higher read range, but higher interference from certain materials

Active versus passive tags:

- **Active tags**
 - Initiator: requires battery, introducing a lifetime
 - More expensive
 - Longer read distances
- **Passive tags:**
 - Waits for incoming signals: no internal source of power (no battery)
 - Relatively cheap in comparison
 - Shorter read distances

RFID Tag Classes; ISO 18000-6C



Tag Class	Frequencies	Active or Passive	Description
Class 0	UHF	Passive	Read-only, need to write at least once
Class 1	UHF or HF	Passive and Active	Write-once, read-many
Class 2	Unspecified	Passive	Indefinite read-write

RFID Reader and Antenna



Desired parameters

- Polarization:
 - Circular
- Beamwidth:
 - Around 120 degrees
- Read distance:
 - Over 1 meter (antenna can be operated at less power to lower the read distance)
- Cost:
 - As low as possible...
- Operation frequency:
 - UHF (865 - 960 MHz)

	Times-7 SlimLine Antenna	Laird Bistatic PRL90209 Antenna	Laird S9025PL Outdoor RFID Antenna	Vulcan UHF Antenna
 Gain	5.5 dBic	9 dBic	5.5 dBic	3.4 dBi
Beamwidth	115	70	100	100
Read distance	4.3 meters	unspecified	unspecified	3 meters
Dimensions	5.9 x 5.9 x 0.55 inches	10.1 x 22.6 x 1.3 inches	5.2 x 5.2 x 0.71 inches	5.4 x 5.4 x 0.13 inches
Cost	\$119.00	\$214.00	\$134.00	\$64.00
Input Power	6 Watts	10 Watts	10 Watts	unspecified

Budget (Proposed/Current)



Item	Quantity	Price
RFID reader	1	\$235
RFID external antenna	1	\$119
Raspberry Pi Zero W	1	\$10
microSD Card	1	\$8
UHF Tags	5	\$2
Camera	1	\$14
Buzzer	1-2	\$1.50
Motion Sensor	1	\$8
Solenoids	4	\$30
PCB	1	\$20 - \$30
Antenna Connectors	2	\$12
Door Materials	-	\$70
3D Printer Filament	1	\$20
External Battery	1	\$50 - 60
TOTAL	N/A	~\$599 - \$620

Division of Work



- Logan:

- Project manager
- Camera research
- Storage
- Mobile application
- Embedded software

- Alexis:

- Wifi
- Buzzer
- Motion sensor
- Database
- Embedded software

- Jordan:

- Door research/design
- Enclosure/door construction
- Locking mechanism

- Hunter:

- RFID (reader, antenna, tag) research/design
- PSU (PCB and battery bank) design
- PCB research and construction